

PRODUCT BRAND	ZTFLOOR™
MANUFACTURER	CHANGZHOU WUJIN ZHONGTIAN COMPUTER-ROOM EQUIPMENT CO.,LTD.
APPLICATION	ZT60-A-SH800 ALL STEEL RAISED ACCESS FLOOR FOR COMMERCIAL OFFICE BUILDING OR EQUIPMENT ROOM

Specification Details

Panel Type	ZT60-A-SH800
Understructure Type	Cornerlock, Freelay Corner Support, Cornerlock Clip-On Stringered, Cornerlock Bolt-On Stringered & Stringered Freelay (50mm to 2,500mm FFH)

Description of the Access Floor System

The SH800 Access Floor will provide a stable platform suitable for the general office & equipment room environments. The floor panels will be constructed utilising draw quality steel for the bottom pan and full-hard steel for the top sheet. The panel will be fully spot welded together (minimum 64 welds in each dome and 20 welds along each flange).

The panel will be die cut to size, phosphate coated (or equivalent) and epoxy powder coated to provide adequate corrosion protection. The panels will be corner locked into place providing equipotential bonding or they can be gravity held with or without stringers.

The cross-head or flat-head pedestal head will provide support for the panel under the flange and picture frame. The pedestal head will also capture the access floor panel providing positive location and additional safety after the corner lock screws are removed.

The raised access floor system will be capable of withstanding various duty static/dynamic loads experienced in the general office and equipment environments.

Objectives Summary

Panel:	<p>Manufactured from cold rolled steel sheet.</p> <ul style="list-style-type: none"> • Top = Full Hard Steel 85-95 RhB (SPCC or Better) • Bottom = Draw Quality (ST14 or better) • The base panel will utilise the ZTFLOOR type A bottom design and incorporate the Corner Lock feature in conjunction with the positive location details. • ZT60-A-SH800 = Steel Gauges: top 0.7-0.9mm and bottom 0.9-1.3mm
Cornerlock:	The panel will be manufactured with four (4) Cornerlock holes to allow the panel to be fixed to the pedestal head. The Cornerlock screws will also provide positive electrical bonding.
Panel Surface Coatings:	Steel substrate is to be finished with a zinc phosphate coating (or equivalent) before Epoxy Powder coat is applied to the external surface of the sized panel.
Surface Colour:	Dark Grey (Epoxy Powder Coat paint)
Core:	hollow
Pedestal Head:	<ol style="list-style-type: none"> 1. Aluminium Die cast head with Cornerlock feature and positive location tab details. Zinc plated steel stud and anti vibration nut assembled and detent feature. The steel stud will be sized to accommodate existing pedestal base. 2. Aluminium Die cast head with Cornerlock feature and positive location tab details. The pedestal head will allow Clip-On stringers to be fixed. Zinc plated steel stud and anti vibration nut assembled and detent feature. The steel stud will

be sized to accommodate existing pedestal base.

3. Flat steel pedestal head will accommodate stringers and allow the Cornerlock function. Zinc plated steel stud and anti vibration nut assembled and detent feature. The steel stud will be sized to accommodate existing pedestal base.

Pedestal Base:	The pedestal base must accommodate the pedestal base steel stud referred to above. FFH = 50mm to 2,500mm
Pedestal Head Gasket:	A Cornerlock Pedestal Head Gasket of suitable rubber construction with permanent attachment to the pedestal head is required only when a Clip-On stringer is attached. This will allow the panel corner to be supported after the stringer is attached.
Pedestal Gasket:	A Freelay Pedestal Head Gasket of suitable rubber construction with permanent attachment to the Cornerlock pedestal head is required. This will provide an isolation barrier between panel and pedestal head. The gasket materials will have an electrical resistance of $<10^4 \Omega$
Stringer Gaskets:	Stringer gaskets must be flexible and clip onto the stringer. They must be manufactured utilising conductive polyethylene materials and have an electrical resistance of $<10^4 \Omega$
Stringers:	The surface coating of Clip-On and Bolt-On stringers must not promote the formation of zinc whiskers. Need to nominate Stringer size to accommodate panel depth and flange.
Environment:	All materials must be environmentally friendly, non hazardous, low emission, no CFC and low impact. There shall be no CO ₂ emissions during or after the production process of any components. No VOC (Volatile Organic Compounds) allowed during the life cycle of the product. Panel and understructure system shall be required to have a minimum recycled content of 40% .
Manufacture	The access floor panels and substructure must be manufactured and quality controlled utilising a recognised quality system. Reference samples must be kept for five (5) years.
Panel Shape	The access floor panel must be die cut to control size, shape and squareness within the tolerance range of "MOB PF2 PS" Platform Floors (Raised Access Floors) Performance Specification
Stability:	The access floor panel and system will remain stable and not alter the performance characteristics when exposed thermal and humidity change.
Effects:	The access floor panel and supporting system shall be resistant to the growth of fungi and micro organisms and attack by insects. The floor system shall be designed to resist vermin attack or infestation. The floor components shall not give off any odours or toxicity.
Fire:	The access floor panel and system will be fire resistant. The test and performance requirements will be in accordance with

- British Standard 476 : Part 7:1997 (To determine the tendency of the surface of a material or a combination of materials to support the spread of flame across its surface and to classify the surface)
- British Standard 476 : Part 6 : 1989 (fire propagation for products)
- British Standard 476 Part 4 : 1970 (Fire Test on Building Materials and Structures-Non-combustibility Test for Materials)

Surface Finish	The access floor shall be capable of having Carpet tile, High Pressure Laminate (HPL), Vinyl, Linoleum and hard surfaces such as stone and ceramic finishes applied. Surface flatness to within 1.00mm
Tolerances	Panel Size = 599.75 x 599.75 +/- 0.25mm (Main Panel Size) Panel Size = 599.75 x 799.75 +/- 0.25mm (Alternative Size) Panel Size = 599.75 x 299.75 +/- 0.25mm (Alternative Size) Panel Size = 609.35 x 609.35 +/- 0.25mm (Main Panel Size) Panel Depth = >30.5mm (dimensioned from under flange to bottom of picture frame) this dimension must be controllable and repeatable and becomes a major feature of the installed access floor system.
Cutting	The access floor panel must be able to be cut on site with standard cutting tools. Dust extraction may be needed in isolated areas. Dust from cutting must not be hazardous to the operator or those in close proximity to the operation.
Installation	The access floor will be rigid, free from vibration and rocking panels within a 3.0mm level over the entire floor area. The access floor pedestals must have a minimum of +/- 25mm of adjustment. Panels will be accurately cut to fit around all permanent features.
Antistatic	The access floor panel and supporting under-structure will provide a dissipative path to earth for the control of static build-up. The general range is 1×10^6 to 1×10^{11} Ohms is acceptable.
Design Life	The access floor system must be capable of withstanding the day to day operating load and conditions of the general office and equipment room environments. The acceptable design life of 25 years is preferred. The core material must not deteriorate or breakdown over time.
Equipotential Bonding	The Cornerlock access floor system must be capable of being electrically bonded so all panels and pedestals have an electrical contact of less than $<1\Omega$.
Air Leakage:	Air leakage on Cornerlock access floor systems should be minimal and restricted where possible. Air Leakage on Clip-On stringered or Bolt-On stringer understructure systems should be restricted to < 0.5 l/s per m ² according to MOB PF2 PS, January 1990 for Air Leakage Rate Test.
Sound Transmission:	The floor system shall have a low airborne transmission of sound.
Recycle:	The access floor panels and substructure must be able to be recycled.
Perforated Airflow Panels:	Perforated steel airflow panels designed for static loads of 1000 lbs. shall be interchangeable with standard field panels and shall have 22% open surface area with or without adjustable damper.
Die-cast aluminum grate panels:	Die cast aluminum grate panels can be interchangeable with standard field panels. Grate panels shall have 54% open area without a damper.
Extruded aluminum air grille:	The extruded aluminum air grill can be interchangeable with full or 1/2-cut standard field panels. The air grill is with or without a damper.
Performance	The raised access floor will have a minimum safety factor of 2 times the concentrated (design) load, and be capable of meeting 800lb static and dynamic loads per CISCA Recommended test procedures for access floors or MOB PF2 PS/SPU : Platform floors (raised access floors). The raised access floor will be subjected to general office and equipment room environments. Work stations, partitions, racking and filing system will generate static loads. Dynamic loads will be aligned with frequent foot traffic at lift lobbies, corridors, walkways and infrequent rolling loads.

PERFORMANCE REQUIREMENTS

The raised access floor system shall meet or exceed all of the Specific Performance Requirements set out below:

General

All components shall be protected against corrosion with the manufacturers standard factory applied protective finishes.

Concentrated Load

The access floor system shall be capable of accepting a point load, over 25mm x 25mm area, of 800lb respectively with a maximum deflection of 2.50mm by Cisca 2003-2004.

Rolling Loads

The access floor system shall sustain the following rolling loads with a maximum total permanent deformation of 1.0mm in the top surface based on the following dynamic load tests by Cisca 2003-2004:

- SH800
 - 350lb for 10 passes - $\varnothing 3"$ x 1 13/16" wheel.
 - 350lb for 10,000 passes – $\varnothing 6"$ x 2" wheel.

Uniform Load:

Panel supported on actual understructure (the system) shall be capable of supporting a uniform load of 13.59KN/sqm placed on the entire area of the panel of SH800 with a maximum deflection of 2.50mm and generating a permanent set of no more than 0.25mm once the load is removed. Note: The uniform load of an raised access floor panel as specified herein should not be confused with the "uniform live load" as specified in seismic area applications. The tests accords to Cisca.

Ultimate Load

The access floor system shall accept minimum SH800 1600lb point load over 25mm x 25mm area without collapse according to Cisca2003-2004.

Impact Load

An impact load imposed on the access floor system by dropping a 40kg sandbag from 1000mm height to 500mm dia. Area shall not cause structural failure according to MOB PF2 PS testing methods.

Pedestal Load

The support pedestals shall individually be capable of sustaining a 22.5kN axial load for five minutes without loss of function or structural failure by Cisca 1986-87.

Stringer Concentrated Load

Stringer shall be capable of withstanding a concentrated load of 450 lbs. placed in its midspan on a one square inch area using a round or square indenter without exceeding a permanent set of 0.010" after the load is removed by Cisca2003-2004.

Electrical Resistance

The antistatic requirement for the access floor will be measured in accordance with MOB PF2 PS:Clause – T43.00. Both surface and bulk electrostatic resistance shall fall in the range of 1×10^6 and 1×10^{11} Ohms.

Dimensional Tolerances

Panel squareness shall be within ± 0.25 mm. Panel dimensions shall be within ± 0.25 mm of nominal size. Concavity or convexity of panels shall not exceed 0.75mm. The tests are according to MOB PF2 PS.

PANEL BACK AND SIDE ELEVATION

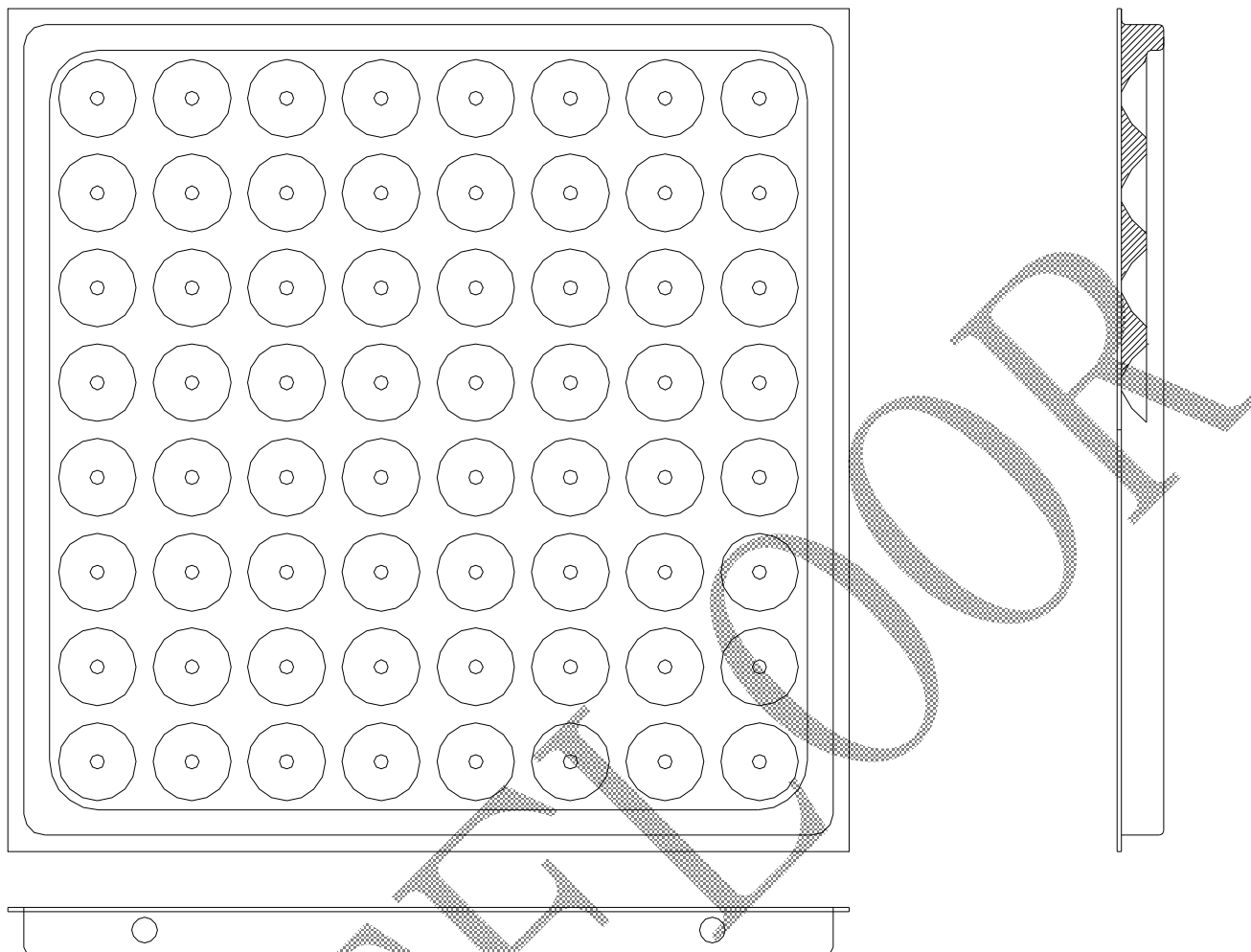

FACTORY LAMINATED PANEL TOP SURFACE

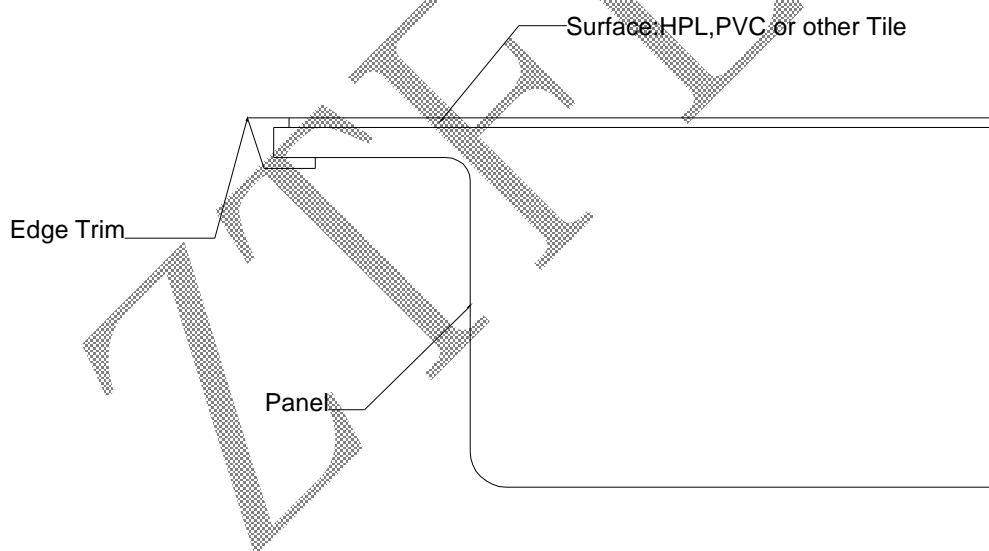
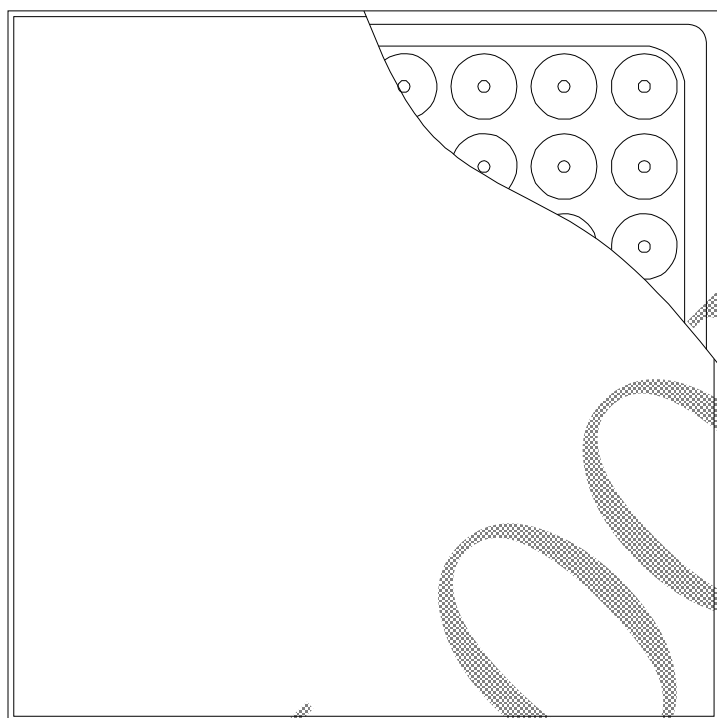

BOLT-ON STRINGER TYPE ACCESS FLOOR INSTALLATION

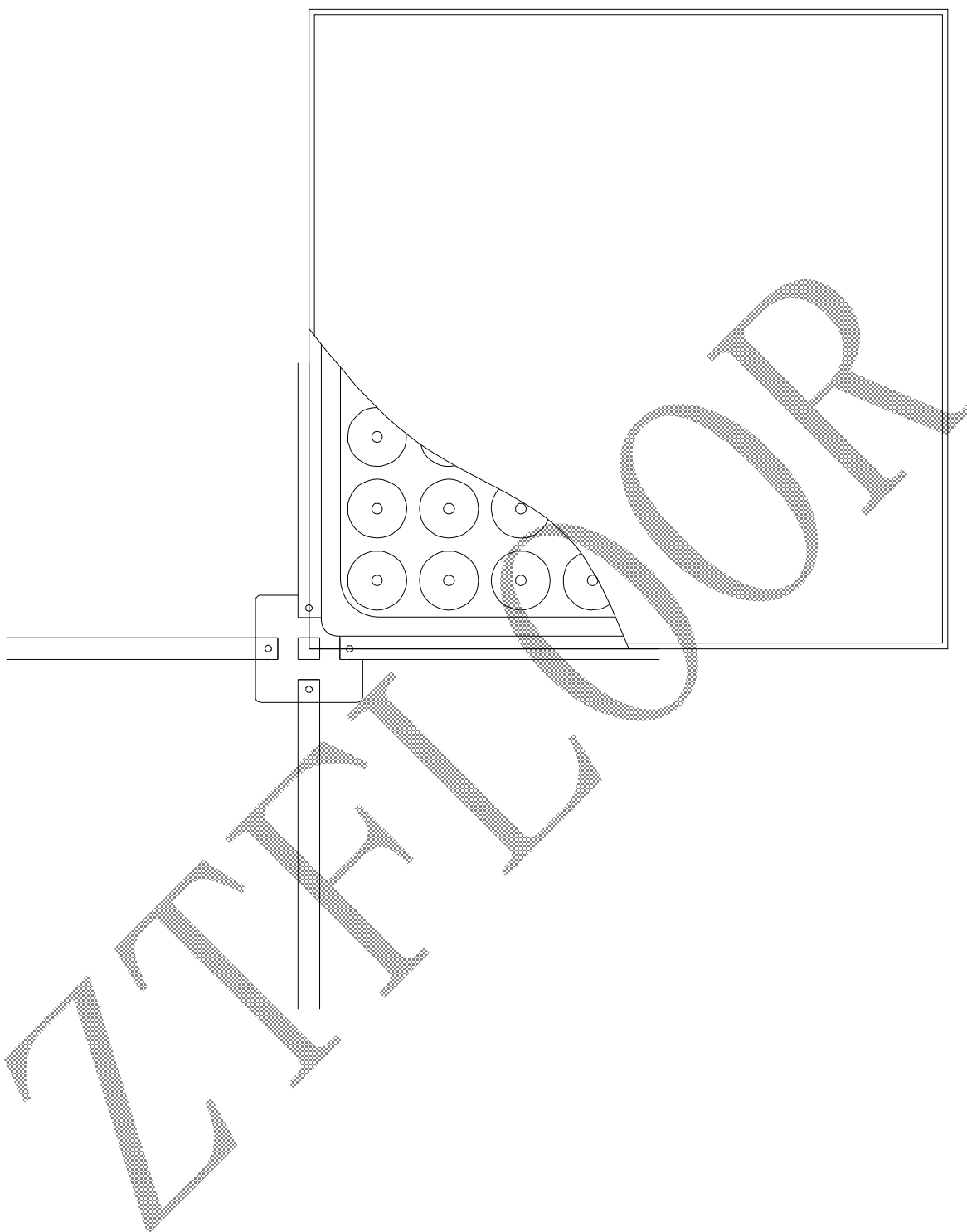

CORNERLOCK ACCESS FLOOR INSTALLATION

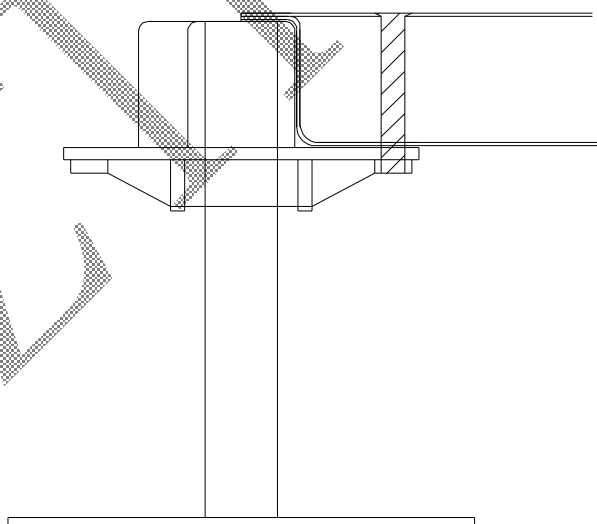
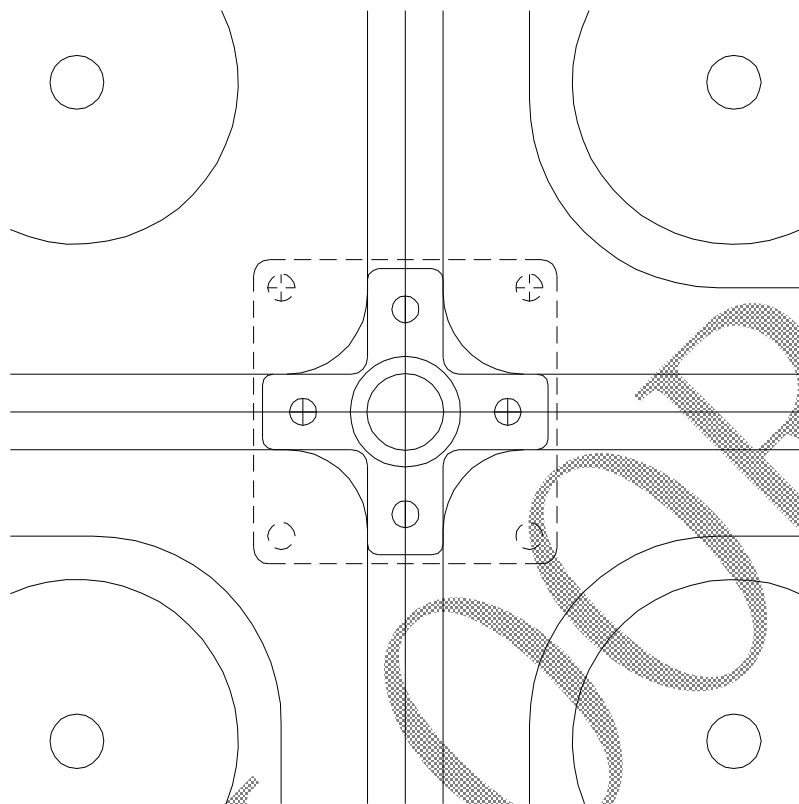

CLIP-ON STRINGER TYPE ACCESS FLOOR INSTALLATION

